



## Quick Guide



*Available For Download*

*Transcend MySleepDash™*



*Transcend User Guides*



<https://mytranscend.com/customer-care/user-guides/>

***Using your Transcend Micro with the MySleepDash app***

*Transcend MySleepDash is a mobile device app that will guide you through the setup process for your new Transcend Micro device. It includes setup videos, helpful information and can track your sleep health progress. The app is not required to operate the Transcend Micro device.*

# Table of Contents

Using your Transcend Micro with the MySleepDash app... 1	1
Indications for Use..... 3	3
Contraindications ..... 3	3
Adverse Effects ..... 4	4
Your Transcend Micro ..... 5	5
Setting Up Your Transcend Micro ..... 6	6
AIRFLEX™ HOSE CONNECTION..... 6	6
CONNECTING THE LAPTOP STYLE POWER SUPPLY 7	7
Connecting Comfort Features..... 8	8
WHISPERSOFT™ MUFFLER ASSEMBLY ..... 8	8
AIRMIST™ HME ADAPTER ASSEMBLY ..... 8	8
Navigating the Device Buttons..... 9	9
BLUETOOTH BUTTON AND LED INDICATORS ..... 10	10
RAMP BUTTON AND LED INDICATORS ..... 11	11
DRY CYCLE BUTTON AND LED INDICATORS..... 11	11
Connecting your Transcend Micro and smart device..... 12	12
CONNECTING YOUR DEVICE ..... 13	13
Starting Therapy ..... 13	13
GentleRise Ramp Function ..... 14	14
Ending Therapy ..... 15	15
Drying Mode..... 15	15
Caring for your Device..... 16	16
Cleaning the Exterior ..... 17	17
Disconnecting Comfort Features ..... 18	18
WHISPERSOFT MUFFLER ASSEMBLY ..... 18	18
Transcend Batteries..... 20	20
Replacing Transcend Micro PureFresh™ Air Filter ..... 20	20
Precautions for Use..... 24	24
Warnings ..... 25	25
Cautions..... 27	27
Environmental Information..... 31	31

## Welcome

The Transcend Micro™ is Transcend's smallest and lightest Continuous Positive Airway Pressure (CPAP) device.



Federal law in the US restricts this device to the sale by, or on the order of, a physician.

## Indications for Use

The Transcend Micro provides positive airway pressure for treatment of obstructive sleep apnea (OSA) in adults weighing over 66 pounds (30 kg). The device is intended for home and hospital/institutional use.

## Contraindications

The Transcend Micro and positive airway pressure therapy may be contraindicated in patients with these conditions:

- Bullous lung disease
- Pathologically low blood pressure, particularly if associated with intravascular volume depletion
- Pneumothorax or pneumomediastinum
- Pneumocephalus has been reported in some users using nasal PAP.

Caution should be used when prescribing PAP for susceptible users such as those with any of these conditions:

- Cerebral spinal fluid (CSF) leaks
- Abnormalities of the cribriform plate
- A prior history of head trauma
- Pneumocephalus

## **Adverse Effects**





*You should report unusual chest pain, severe headache, or increased breathlessness to your prescribing physician. An acute upper respiratory tract infection may require temporary discontinuation of treatment.*

*The following side effects have been reported by users of airway delivery devices during CPAP therapy.*

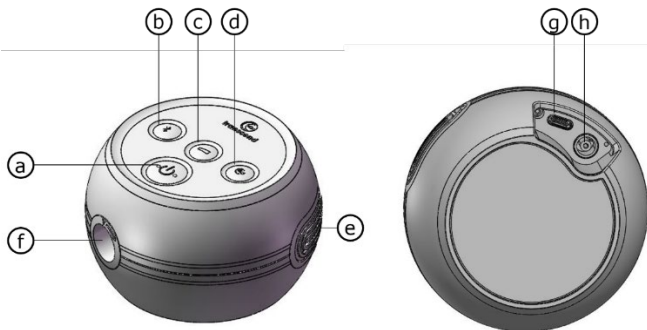
- *congestion or mucus in the throat*
- *sneezing or cough*
- *bloating*
- *nocturnal wakening*
- *feelings of claustrophobia*
- *burn*
- *irritation/dryness of the mouth, nose, or throat*
- *nosebleed*
- *skin rashes*
- *eye irritation*
- *ear or sinus discomfort*

## Your Transcend Micro



- a. Power button 
- b. Bluetooth button 
- c. Pressure ramp button 
- d. Dry cycle button 
- e. Air filter cover
- f. Air outlet
- g. USB-C data port
- h. Power supply inlet

# Setting Up Your Transcend Micro

## AIRFLEX™ HOSE CONNECTION

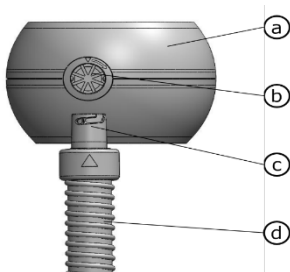

- a. Transcend Micro device
- b. Air outlet
- c. Air hose coupler
- d. AirFlex hose

1. Connect the hose firmly to the air outlet by inserting the hose coupler into the air outlet on the device.
2. Locate the arrow on the air hose coupler and arrow on the device.
3. Align the arrows and gently insert and twist the air hose coupler clockwise until connector is seated securely into the device. The image below indicates a fully secured hose with the hose arrow below the parting line of the device
4. Connect your mask to the opposite end of the hose.
5. To remove the hose simply turn it counterclockwise and pull gently away from the device.

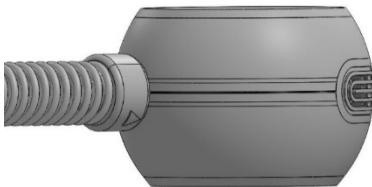

## CONNECTING THE LAPTOP STYLE POWER SUPPLY

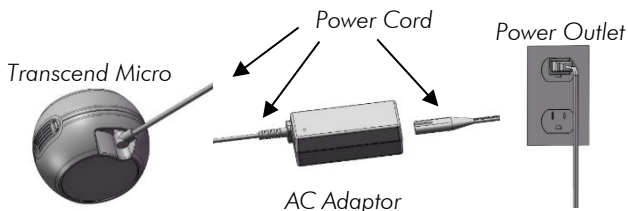

1. Connect the power cord to the power inlet at the bottom of the device.
2. Connect one end of the power cord into the AC adapter and the other end into the power outlet.
3. When connected to power, the device power-up LED flash sequence will begin. Once the sequence is complete, the green Power LED light will remain on.

## CONNECTING THE WALL MOUNT STYLE POWER SUPPLY

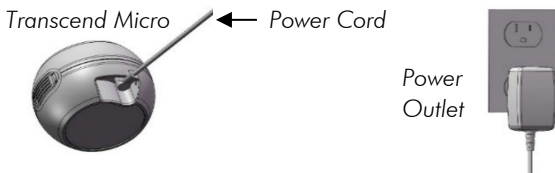

1. Connect the power cord from AC adapter into the power inlet at the bottom of the device.
2. Connect power cord from device power inlet directly to power outlet.

**NOTE:** Ensure the power cord is accessible so that it can be easily unplugged from the wall.



## Connecting Comfort Features

### WHISPERSOFT™ MUFLER ASSEMBLY

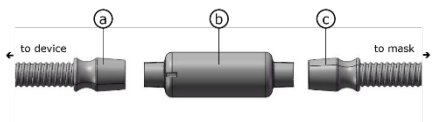

- a. Short air hose
- b. WhisperSoft muffler
- c. Long air hose

1. Attach the short hose to the device.
2. Attach the short hose to the WhisperSoft muffler.
3. Attach one end of long (mask) hose to the other end of the muffler and then attach the other end to the mask or HME (Heat/Moisture Exchanger).

### AIRMIST™ HME ADAPTER ASSEMBLY

The Transcend AirMist HME assembly is sold separately, and it is not included with the Transcend Micro system.

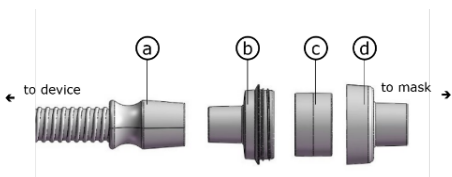

- a. Long air hose
- b. HME adapter bottom
- c. HME cartridge
- d. HME adapter

1. Remove the HME cartridge from foil package. Handle by the plastic shroud not the foam core.
2. Unscrew the HME adapter bottom from the HME adapter top and place the HME cartridge inside the HME adapter bottom.
3. Place the HME adapter top onto the HME adapter bottom and gently turn the top until tight.

4. Securely attach the HME adapter bottom to your hose.
5. Securely attach the HME adapter top to your mask.

## Navigating the Device Buttons

### CONTROL PANEL

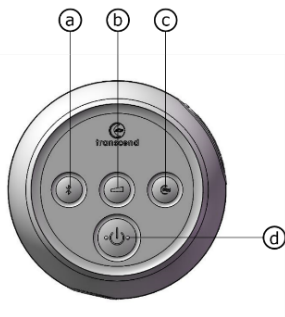

- a. Bluetooth
- b. Pressure ramp
- c. Dry cycle
- d. Power

### POWER BUTTON AND LED INDICATORS

#### Standby Mode

When the device is plugged in, it will be in Standby Mode.

- The LED glows green, indicating that the device has power.
- Pressing the power button transitions the device to Therapy Mode.
  - All LEDs will turn off.
  - The blower will start and the device will begin regulating pressure.

## Therapy Mode

When the device is powered and in Therapy Mode:

- The LED is off.
- Pressing the power button transitions the device to Standby Mode.
  - The LED glows green.
  - The blower stops.

## BLUETOOTH BUTTON AND LED INDICATORS

### Standby Mode

Pressing the button toggles Bluetooth communication between enabled/disabled.

<i>Bluetooth indicator light is blue</i>	<i>Bluetooth communication is enabled but there is not an active connection with a mobile device.</i>
<i>Bluetooth indicator light is green</i>	<i>Bluetooth communication is enabled and there is an active connection with a mobile device.</i>
<i>Bluetooth indicator light is white</i>	<i>Bluetooth communication is disabled.</i>

### Therapy Mode

Pressing the Bluetooth button has no effect while in Therapy Mode.

<i>Bluetooth indicator light is off</i>	<i>Therapy Mode is on.</i>
---	----------------------------

## RAMP BUTTON AND LED INDICATORS

### **Standby Mode**

- The LED glows blue if the Ramp is configured and auto-ramp is enabled.
  - The LED is off if Ramp is not configured, or Auto Ramp is disabled.
- Pressing the button when Ramp is not configured has no effect.
  - See Transcend desktop software user guide to configure <https://mytranscend.com/customer-care/user-guides/>
- Pressing the button when Ramp is configured toggles Auto Ramp between enabled and disabled.

### **Therapy Mode**

- The LED is off.
- If Ramp is active, pressing and holding the button accelerates Ramp increase.
- If Ramp is configured but not active, pressing the button starts Ramp.
- If Ramp is not configured, pressing the button has no effect.

## DRY CYCLE BUTTON AND LED INDICATORS

### **Standby Mode**

- The LED is off when Drying Mode is off.
- The LED glows blue when Dry Cycle is on.

- Pressing the Dry Cycle button toggles between on and off.

## **Therapy Mode**

- The LED is off.
- Pressing the button has no effect.

## **Connecting your Transcend Micro and smart device**

Before connecting Transcend Micro to a smart device, ensure that the latest version of the MySleepDash app is installed on the smart device. The app is available for download from the App Store or Google Play.

To connect your smartphone and the app:

1. Ensure your Transcend Micro device is set up correctly and plugged into a power source.
2. On your smart device, enable Bluetooth.
3. Open the MySleepDash app.
4. The first time you open the MySleepDash app, you will be asked to login or create an account using your email.
5. Once selections are complete on the Create Account page, tap submit.
6. After creating your account, you will be required to login using the email and password you just set up.
7. The next step will be to connect your Transcend Micro device to the MySleepDash app.

## CONNECTING YOUR DEVICE

- *Ensure Bluetooth is enabled on the Transcend Micro device.*
- *On the MySleepDash app, tap continue on the welcome page.*
- *Open the QR scanner on your phone. You may be required to allow the device to use the camera features.*
- *Locate the QR code on the bottom of the Transcend Micro device and scan using your smart device.*
- *Click add to complete adding your device.*
- *The blue light on the Transcend Micro will turn green.*
- *Your device is now connected.*

## Starting Therapy

1. *Connect the Transcend Micro to a power source and allow it to enter Standby Mode.*
2. *Be sure your mask fits firmly and in place before starting therapy.*
3. *Press the Power button or breathe normally to engage SleepStart, our auto start feature. Therapy will begin when the blower delivers or ramps to the prescribed therapy pressure.*

**NOTE:** *Some masks are configured differently. Due to this variability SleepStart may not function.*

**NOTE:** *If therapy is interrupted by a power failure, the device will automatically restart therapy once power is restored.*

## GentleRise Ramp Function

The GentleRise feature lets you acclimate to air flow by starting at a lower pressure and gradually increasing to the prescribed pressure setting as you fall asleep.

To accelerate the rate of the pressure increase during GentleRise:

- Hold the Ramp button down until the device reaches a comfortable therapy pressure.
- When the Ramp button is released, the device will continue in Ramp Mode until it reaches the prescribed therapy pressure.
- To end GentleRise early, hold down the Ramp button until the prescribed therapy pressure is reached.
- If Ramp is no longer desired, disable it via software or app.

**NOTE:** Once installed and connected, you may use the MySleepDash app to change ramp settings on compatible Micro devices. Alternatively, to adjust ramp starting pressure or duration see the Transcend Micro software manual available on the Transcend website ([mytranscend.com](http://mytranscend.com)).

## AirRelief Function

The AirRelief function is a feature that decreases therapy pressure on exhalation. This is designed to provide additional comfort to the user by reducing the amount of resistance they experience as they exhale.

There are four AirRelief settings: OFF, 1, 2 or 3. Each setting progressively increases the amount of pressure relief from none to maximum.

Once installed and connected, you may use the MySleepDash app to change air relief settings on compatible Micro devices. Alternatively, see the Transcend Micro software manual available on the Transcend website ([mytranscend.com](http://mytranscend.com)) and follow the steps to change settings.

## **Ending Therapy**

Remove your mask and press the power button to end therapy.

## **Drying Mode**

At the end of each therapy session, it is recommended that the user initiate the Drying Mode function to dry the attached air hose and accessories.

To initiate Drying Mode:

- Press the Drying Mode button.
- When in Drying Mode, the blower will run at a low speed for 30 minutes.
- During Drying Mode, the Drying Mode LED will continue to glow.
- After 30 minutes, the blower will turn off and the device will enter Standby Mode.



## Caring for your Device

**Warning:** *Unplug the Transcend Micro device before cleaning and make sure it is dry before plugging it in again. Do not perform any cleaning or maintenance tasks while the device is in operation. Damage caused by improperly caring for your device may not be covered by Transcend's limited warranty.*

- *Do not submerge the Transcend Micro device, power supply or power cord in water.*
- *Prevent water from entering any openings of the device.*
- *Do not use harsh or abrasive cleaning agents to clean the device or any components.*
- *Do not attempt to sterilize the Transcend Micro device.*
- *Do not place cleaning materials, such as a cloth or liquid, into the device air inlet or air outlet connector.*
- *Do not open or modify the device. There are no user-serviceable parts inside the device. Servicing and repairs should only be performed by an authorized Transcend person.*
- *Do not use chlorine, bleach, or scented cleaning solutions, antibacterial or moisturizing soaps or oils, including scented oils, to clean the device or its components. These solutions may damage the device or reduce its life.*
- *Exposure to smoke, including cigarette, cigar or pipe smoke may damage the device.*
- *Exposure to ozone or other gases may damage the device.*

## **Cleaning the Exterior**

Follow these instructions to clean the exterior of the Transcend Micro device.

1. *Mix a solution of 5% mild liquid detergent in distilled water (1.6 fl. Oz. liquid detergent per quart of distilled water). Mild detergent should contain biodegradable anionic surfactants and no phosphate.*
2. *Submerge a lint-free cotton cloth into the detergent solution.*
3. *Wring excess water from the cloth then wipe the exterior surface of the Transcend Micro device for approximately 20 seconds using a gentle back and forth wiping motion. Ensure contact with all accessible surfaces to adequately remove any soil buildup.*
4. *Rinse the cloth in clear water to remove residual cleaning solution.*
5. *Wring excess water from the cloth and wipe the Transcend Micro using a gentle front to back wiping motion to remove any detergent solution remaining on the surface.*
6. *Wipe the device with a dry, lint-free cotton cloth until the device is fully dry.*

## Disconnecting Comfort Features

### WHISPERSOFT MUFLER ASSEMBLY

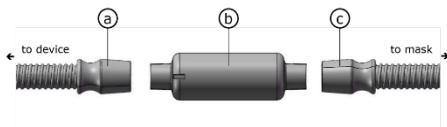

- a. Short air hose
- b. WhisperSoft muffler
- c. Long air hose

1. Remove the short air hose from the device, by twisting the connector left or counterclockwise and pulling the hose away from the device. Disconnect the other end of the short air hose from the muffler.
2. Remove the muffler from one end of your long hose and your mask from the other end of the hose.
3. After following the cleaning process, refer to steps in the Connecting Comfort Feature section to reassemble the muffler.

## Cleaning of Accessories

The following accessories should be cleaned with a 5% solution of mild dishwashing liquid, detergent in distilled water (1.6 fl. oz. liquid cleaning detergent per quart of distilled water). Mild detergent should contain biodegradable anionic surfactants and no phosphate.

Clean the device and its components as shown in the schedules below to maintain the quality of your device and to help prevent the growth of germs that can adversely impact your health.

<b>Accessory</b>	<b>Periodic Cleaning Cycle</b>	<b>Product Service Life</b>
AirFlex Hose	Weekly	3 Months
WhisperSoft Muffler	Weekly	3 Months
AirMist HME Adapter	Weekly	3 Months

Follow these steps to clean the accessories.

1. Fully immerse the accessory in the cleaning solution. DO NOT immerse the Transcend Micro device.

**NOTE:** The HME Cartridge must be removed prior to cleaning the HME Adapter. The HME cartridge cannot be cleaned. Discard it after 7 days of use.

2. While immersed, thoroughly wipe the surface with a lint-free cotton cloth. Apply firm pressure and ensure contact with all accessible connection surfaces to adequately remove soil buildup.
3. Clean the inside of the accessory by lifting then lowering the ends of the accessory, while the accessory is filled with cleaning solution.
4. Rinse accessory by immersing in distilled water. Move the accessory in a back-and-forth motion for approximately 10 seconds to remove cleaning agent residue.
5. Dry the outside of the accessory with a dry, lint-free cotton cloth. Allow the accessory to air dry until the inside is dry. The length of drying time will depend on ambient conditions.

## Transcend Batteries

See the User Guide on [myTranscend.com](http://myTranscend.com) for guidance information on setup, use and caring for Transcend batteries.

### Replacing Transcend Micro PureFresh™ Air Filter

The Transcend Micro PureFresh air filter should be replaced at a minimum every three months.

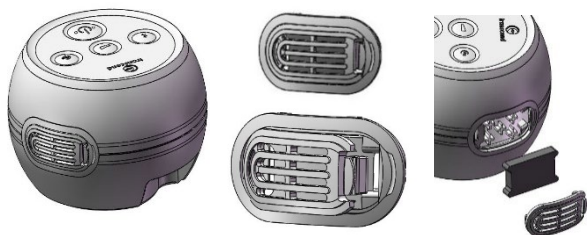

1. Depress the tab on the right side of the filter cover to remove it from the device
2. Remove the filter and discard. Replace it with a new filter.
3. Reattach the filter cover by inserting the left side into the device and then clicking the right-side in.

## Troubleshooting

<b>PROBLEM AND POSSIBLE CAUSE</b>	<b>RECOMMENDED SOLUTION</b>
<b>Discomfort due to a feeling of high pressure</b>	
Device pressure may be set too high	Breathe slowly through your nose with your mouth closed.  Use the ramp pressure, if available.  If the pressure remains problematic, contact your homecare provider.
<b>Discomfort due to a feeling of low pressure in mask</b>	
Device set too low	Contact homecare provider for setting change
Excessive leaks around hose or mask	Check hose, mask, and any accessories in the breathing circuit for air leaks and proper fit.
<b>Dry nose or throat irritation</b>	
Dry air	Add humidity to the room.  Replace HME if being utilized. Ensure proper placement of HME.  Contact your homecare provider.
Dirty air path accessory	Follow cleaning instructions for accessories.
Dirty air filter	Change the Air Filter.
<b>Device control panel LEDs don't flash or illuminate when the power supply is connected to the device</b>	

Power source is not properly connected	Check all power connections and verify if the LED light on the power supply is illuminated.
AC power may not be active.	Use another power outlet.  Confirm outlet is not controlled by a wall switch.
No airflow from the device OR Device motor failure or electronics failure	Contact the homecare provider's technical service department.
<b>All LEDs flash two times then pause, then flash again</b>	
Device detects an operating error	Hold down the power button until all LEDs stop flashing. Release the power button, the device will reset and power up in Standby Mode.  Check hose, mask, and any accessories in the breathing circuit for air leaks and proper fit.  If problems persist, contact your homecare provider.
<b>Device shuts down during therapy</b>	
Improper seal of external hardware (mask, tubing); or use of external hardware past recommended service life	Verify all external equipment in breathing circuit is sealed correctly to ensure a proper seal. Check hose for leaks.  Follow mask manufacturer recommendations for fit and seal.
<b>Device shuts down during therapy</b>	

Breathing circuit not assembled correctly	<p>Replace any external hardware exceeding recommended service life.</p> <p>If problems persist, contact your homecare provider.</p>
<b>All LEDs flash four times then pause, then flash again</b>	
Device detects an operating error	<p>Hold down the power button until all LEDs stop flashing. Release the power button, the device will reset and power up in Standby Mode. If the LEDs begin to flash again, contact your homecare provider.</p>
<b>Droplets of water in my mask after therapy</b>	
Excess condensation from breathing	<p>Run drying mode after therapy.</p> <p>Utilize in a less humid environment (dehumidifier).</p>
<b>Bluetooth will not connect</b>	
Bluetooth disabled (White LED light)	<p>Push Bluetooth button to enable (Blue LED light).</p>
App not downloaded or issue with the app/phone function	<p>Verify app is downloaded and installed, the phone supports Bluetooth Low Energy and has Bluetooth enabled.</p>
Bonded pairing information stale	<p>Follow instructions on the phone to forget the Bluetooth connection. On the device, hold down the BT button until the BT LED flashes from blue to yellow once (about 5 seconds).</p>
<b>SleepStart is not functioning</b>	



<i>Breathing circuit has excessive leaks</i>	<i>Check hose, mask and any accessories in the breathing circuit for air leaks and proper fit.</i>
<i>User not breathing deeply enough to trigger SleepStart</i>	<i>Ensure deep breath is taken with mask securely fitted or press Power button to start therapy.  If the problem persists, call your homecare provider's technical service department.</i>
<i>Bluetooth LED is red (not flashing) all other LEDs are off. Device does not respond to button presses</i>	<i>Disconnect power, wait at least 15 seconds, re-connect power.  If the problem persists, call your homecare provider's technical service department</i>

## **Precautions for Use**

*This section describes the warnings and cautions associated with use of the Transcend Micro. The following guidelines apply to this document:*

- Warning**      *Indicates the possibility of serious injury or death to yourself or others.*
- Caution!**    *Indicates the possibility of minor injury or damage to the equipment.*
- NOTE:**        *Indicates a tip, explanation, or feature to aid in understanding, or efficient operation of the device.*

## Warnings

- Do not allow water to enter this device. Transcend Micro should not be exposed to environmental conditions where the system may get wet.
- This device is not intended for life support.
- The Transcend Micro must be set up and adjusted by a trained provider before being used for therapy ramp and pressure.
- The air temperature produced by this device can be as much as 10°F higher than the temperature of the room. Exercise caution if the room temperature is warmer than 90°F (32°C).
- Do not block or otherwise obstruct the exhalation ports of the mask. Follow the manufacturer's instructions, included with your mask.
- This equipment is not suitable for use with oxygen or in the presence of a flammable anesthetic mixture with air or oxygen, or with nitrous oxide. Sources of oxygen must be located more than 1 meter from the equipment to avoid the risk of fire and burns.
- The Transcend Micro is only to be used with the supplied or recommended accessories. Use of accessories not recommended may result in increased electromagnetic emissions or decreased electromagnetic immunity of the PAP system and may be potentially unsafe.
- The Transcend Micro is not defibrillation proof.
- Do not attempt to sterilize Transcend Micro.

- *If the device is to be used by multiple patients a main flow bacteria filter should be installed in-line between the device and the mask to prevent contamination.*
- *The device should be used only with masks and connectors recommended by Transcend or a health care professional. A mask should not be used unless the device is turned on and is properly delivering ramp or therapy pressure. The exhalation port(s) associated with the mask should never be blocked. Explanation of the Warning: The device is intended to be used with masks or connectors specifically designed to have exhalation ports to allow continuous flow of air out of the mask. When the device is in operation, air flow from the device flushes exhaled air out through the mask exhalation port. When the device is not operating, however, fresh air will not be provided through the mask and exhaled air may be rebreathed.*
- *Failure to use a mask or accessory that minimizes rebreathing of carbon dioxide or permits spontaneous breathing can cause asphyxiation. Only use masks which comply with ISO 17510.*
- *Do not position the equipment in bed. Covering breathing tubes with a blanket or heating them can affect the quality of therapy or injure the user.*
- *To prevent disconnection of the tubing during use only Transcend supplied hoses or hoses in compliance with ISO 5367 or ISO 80601-2-74 should be used.*
- *Strangulation hazard from power cord and air tube. These can become wrapped around the neck and STRANGLE. Keep power cord and air tube more than 3*

feet from a baby's crib and out of baby's reach. Keep cord and tube out of children's reach.

- Small parts are unlikely to be expelled from the Transcend Micro enclosure, but in case of severe damage internal components may fragment and create a swallowing or choking hazard if they get out of the enclosure.
- Use of this equipment adjacent to or stacked with other equipment should be avoided because it could result in improper operation. If such use is necessary, this equipment and the other equipment should be observed to verify that they are operating normally.
- Use of accessories, transducers, and cables other than those specified or provided by the manufacturer of this equipment could result in increased electromagnetic emissions or decreased electromagnetic immunity of this equipment and result in improper operation.
- Portable RF (radio frequency) communications equipment (including peripherals such as antenna cables and external antennas) should be used no closer than 30 cm (12 inches) to any part of the Micro device.

## **Cautions**

- Federal law in the US restricts this device to the sale by, or on the order of, a physician.
- Power the Transcend Micro only with the Transcend supplied power supplies or batteries.
- Discontinue use of the Transcend Micro and contact your physician if respiratory or skin irritations occur.
- Do not introduce objects into the Transcend Micro air inlet or air outlet.

- *Inspect the power supply for signs of wear or damage before each use. Replace the power cord if necessary.*
- *Transcend recommends replacing the hose after every three months of use.*
- *To protect the environment, some parts and accessories of the Transcend Micro, including optional batteries, must be disposed of in accordance with local regulations.*
- *The equipment must not be covered or positioned in such a way that adversely affects the performance of the equipment, as it may also create a safety issue.*

*Examples of this would include:*

- *The equipment must not be positioned in a bed.*
- *The equipment should not be placed anywhere other than on a firm, flat surface.*
- *Do not position in a location where pets or children can access equipment.*
- *Do not position near an open window or other location where dust, or pests (insects) can affect equipment safety and/or performance.*
- *Do not position next to a curtain that blocks the flow of cooling air, thereby causing the equipment to overheat.*
- *Do not block the air intake port, thereby interfering with therapy.*

## Symbols



Ramp functionality



Drying Mode



Power



Caution

**IP22**

Protected against finger-sized objects and against dripping water when tilted 15 degrees from specified orientation



Type BF Applied Part



Upper and lower temperature limits



Separate collection for electrical and electronic equipment per EC Directive 2002/96/EC. – Waste Electrical and Electronic Equipment (WEEE).



Consult instructions for use

**Rx Only**

Prescription only. U.S. federal law restricts this device to sale by or on the order of a physician or properly licensed practitioner.



Precedes reference or item number



Batch code



*Date of Manufacture*



*Manufacturer*



*Fragile, handle with care*



*Keep dry*



*Serial Number*



*Bluetooth*



*Regulatory Compliance Mark –  
indicates compliance with Australian  
Radiocommunications Notice 2014 and  
Radiocommunications Act 1992*



*Wireless. FCC part 15 compliant.  
RTCA/DO-160 Section 21 Category M  
compliant & FAA compliant.*



*Shipping and storage temperature  
limitation.*



*Shipping and storage relative humidity  
limitation.*



*UL Seal of Approval demonstrating  
quality, safety, and professional  
manufacturing of medical product.*

## **Environmental Information**

*This device should be disposed of separately, not as unsorted municipal waste. To dispose of your device, you should use appropriate collection and recycling systems available in your region. If information on these disposal systems is needed, please contact your local waste administration. If you require information on the collection or disposal of your device please contact Transcend, your homecare provider, or go to [MyTranscend.com/environment](http://MyTranscend.com/environment).*

### *California Perchlorate Information:*

*The coin-cell battery within this device may contain Perchlorate Material – special handling may apply. See: [www.dtsc.ca.gov/hazardouswaste/perchlorate](http://www.dtsc.ca.gov/hazardouswaste/perchlorate)*



## Notices



Notice	<i>The information contained in this document is subject to change without notice.</i>
Trademark	<i>The moon logo, Transcend Micro, WhisperSoft, AirFlex, PowerAway, AirMist, MySleepDash, and Transcend are trademarks and/or registered trademarks of Transcend Inc.</i>
Copyright	© Copyright 2023 Transcend Inc. All Rights Reserved.

## Contact Transcend Inc.

Corporate  
headquarters



Transcend Inc.  
103 Osborne Road NE  
Fridley, Minnesota 55432 USA

Email

[info@MyTranscend.com](mailto:info@MyTranscend.com)

Web

<http://www.MyTranscend.com>

Telephone

651.621.1800

Toll-free telephone

877.621.9626

Fax

651.204.0064

**Rx only**

104143 REV E 2023-03

